

ROHS COMPLIANT

REV	DESCRIPTION	DATE	APP
G	CHANGE WIRE LIST	2008/10/07	

REV	DESC	DATE	APP
A	FIRST EDITION	2008/05/26	
B	CHANGE CONNECTOR AND TOOL	2008/07/18	
C	CHANGE SCREW AND DESIGN	2008/07/23	
D	CHANGE PIN AND ADD SCREW	2008/07/28	
E	REMOVE SCREW	2008/07/29	
F	CHANGE TOOL AND CONNECTOR	2008/09/19	

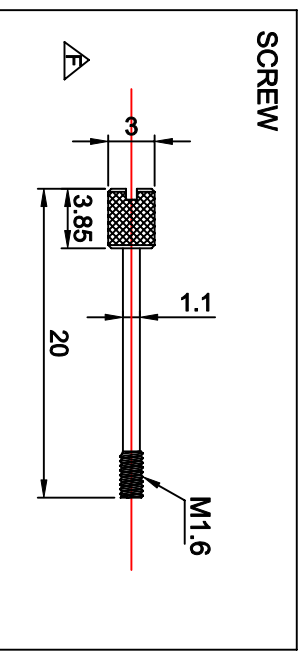
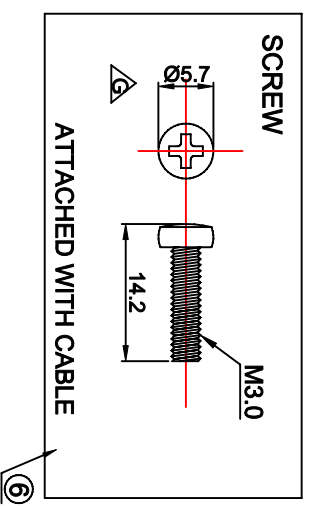
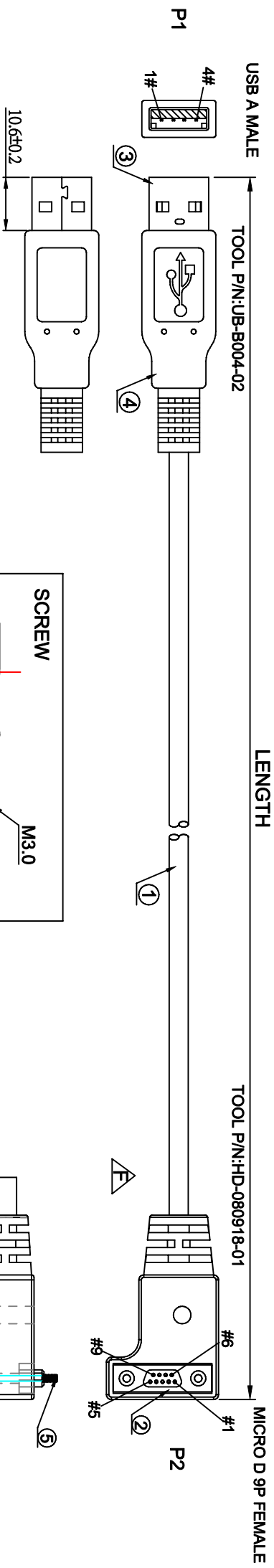

NOTES:
 1. PIN ASSIGNMENT SEE TO WIRE LIST.
 2. ELECTRICAL TEST CONDITION:
 (a). 100% OPEN, SHORT & MISWIRE TEST,
 (b). INSULATOR RESISTANCE: 20 Mohm MIN.
 DC 300V 0.01sec/0.03sec.
 (c). CONTACT RESISTANCE: 3 ohm MAX.

ITEM	QTY	PART NUMBER	DESCRIPTION
6	1		SCREW: M3 5.7*14.2MM.
5	2		SCREW: M1.6 3.0*20MM, NICKEL PLATED.
4		G0001	ALL CONNECTOR OVERMOLD BLACK PVC.
3	1	A0114	USB A TYPE .MALE .GOLD PLATED 30" SOLDER TYPE.
2	1		MICRO D 9P FEMALE, SOLDER TYPE, BLACK INSULATOR, WITH M1.6 AND M3 SCREW.
1	1	E0849 H7304R	28AWG*1P+26AWG*2C-AM-SP-FPP. OD: 4.5MM UL20276 BLACK PVC JACKET.

PIN ASSIGNMENT

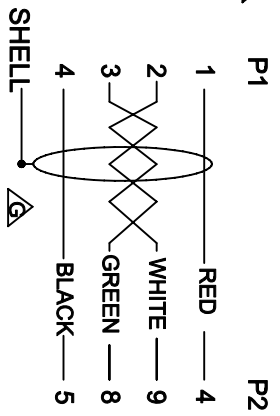

COMPONENTS EXPRESS INC.
 PH: 1 800-578-6695
 www.ComponentsExpress.com

REV.:	DWG NO.:	CY-S-0375
G	CUSTOMER:	CEI

DRAWN BY: CAO JIA WEI
 CHECK BY: JAMES
 APP. BY: FREE

SCALE	UNIT	SHEET
FREE	mm	1/1